

One Relay for Comprehensive Protection, Automation, and Control of All Your Capacitor Banks

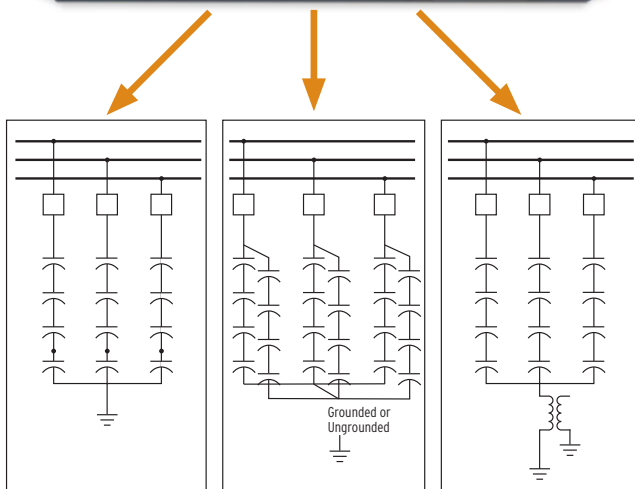

Grounded capacitor bank with low-voltage tap.

Double-wye grounded or ungrounded capacitor bank.

Ungrounded capacitor bank with neutral-voltage sensing.

Features and Benefits



Implement Protection for a Variety of Applications

Protect grounded and ungrounded, single- and double-wye configurations. Use sensitive phase- and neutral-voltage differential elements and phase- and neutral-current unbalance elements to provide reliable protection. Simplify relay settings using the application-based settings to automatically select typical protection elements for your application.

Provide Flexible Multibank Control

Select from voltage, power factor, VAR, or time-of-day/day-of-week control schemes for up to three capacitor banks. Prevent equipment damage using control instability (hunting) detection. Apply three independent sets of trip logic for staged-bank applications.

Simplify Settings Calculations

Automatically perform calculations for application-based settings using IEEE C37.99 based settings assistant software.

Save Time Identifying Faults

Find faulty capacitor units by using advanced faulted phase and section identification logic.

Improve Power System Reliability and Stability With Built-In Synchronasor Measurement System

Obtain real-time measurements of electrical quantities. Provide local control based on wide-area measurements.

High-Performance Features

Worldwide, ten-year product warranty and -40° to +85°C operating temperature range are the best in the industry.

Easy-to-use keypad simplifies navigation and set-point adjustment.

24 detailed, programmable tricolor target LEDs, with user-configurable labels, give fast and simple information to assist dispatchers and line crews in rapidly restoring power.

Auxiliary trip and close buttons are electrically separate from the relay, allowing breaker control even when the relay is powered down.



Select your own system bay configuration, and control one breaker and up to 10 disconnect switches using the built-in mimic diagrams that include up to six programmable analog quantities for readouts.

Easily visualize preferred analog quantities and control breakers through the front-panel mimic display.

12 programmable operator pushbuttons and LEDs along with configurable labels provide local switches to replace traditional panel switches.

Protection

- Voltage Differential
- Current Unbalance
- Unbalance Compensation
- Over-/Undervoltage
- Over-/Underfrequency
- Breaker Failure
- Instantaneous Overcurrent
- Time-Overcurrent
- Expanded SELogic® Control Equations
- 8 kHz Oscillography
- Directional Overcurrent
- Harmonic Metering

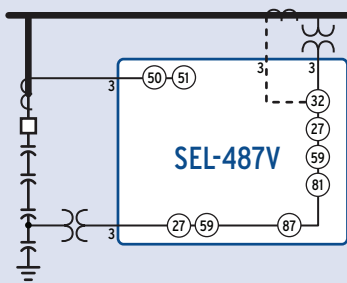

Automation

- Ethernet Communications Protocols
 - FTP
 - Telnet
 - DNP3 LAN/WAN
 - IEC 61850
 - IEEE C37.118 Synchrophasors
 - PRP
 - SNTP
- Serial Communications Protocols
 - SEL MIRRORING BITS®
 - SEL Fast Message
 - DNP3
 - IEEE C37.118 Synchrophasors
 - IRIG-B

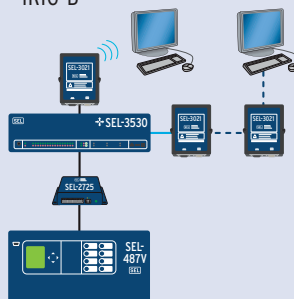

Control

- Automatic Capacitor Bank Control*
 - Voltage
 - VAR
 - Power Factor
 - Time-of-Day/Day-of-Week
 - Instability Detection
- Local HMI Mimic Displays With Control and Metering
- Local and Remote Control Bits
- Programmable Automation and Protection Logic
- VSSI Recording*

*Only available on SEL-487V-1

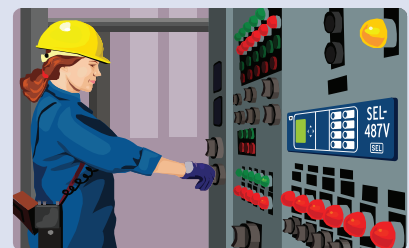

Faulted-Phase Identification Protection

Find Faults Faster

Reduce the time needed to identify faulted capacitor bank units with the faulted phase and section identification logic in the SEL-487V. This logic provides discrete indications for the phase and section of the faulted capacitor units. For voltage differential applications, the phase angle of the differential voltage determines the faulted phase and the sign of the differential voltage determines whether the fault is above or below the tap. For current unbalance applications, the phase angle of the unbalanced current determines the phase and bank where the fault is located.



Control

Eliminate the Need for a Separate Capacitor Controller—Choose the Optional SEL-487V Control Feature

Obtain full control of your capacitor banks without the additional time, wiring, and installation of an additional device. Maintain system voltage, VAR, or power factor (PF) levels with deadband control functions, which include auto and manual as well as local and remote control capabilities. Apply control instability detection for alarm or blocking of control operations. Implement the time-of-day/day-of-week control feature to synchronize capacitor bank insertion with peak VAR demand periods for any weekday or weekend period.

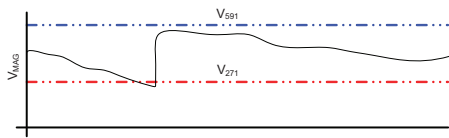

Figure 1. Voltage Control Deadband Characteristics

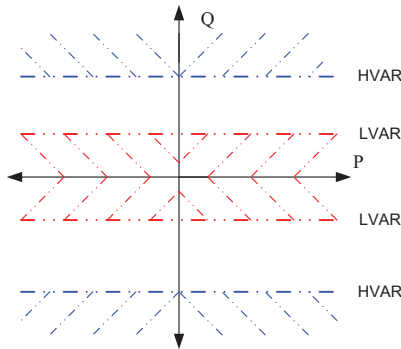

Figure 2. VAR Deadband Control Characteristics

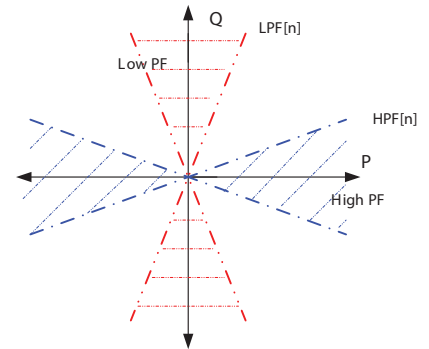

Figure 3. Power Factor Deadband Control Characteristics

Settings

Minimize Setup Costs and Commissioning Time With Application-Based Settings

The SEL-487V saves time by automatically providing the recommended capacitor bank primary protection elements based upon capacitor bank nameplate and configuration settings. The relay only displays applicable protection elements (differential voltage, differential neutral voltage, neutral-current unbalance, and phase current unbalance protection) for easy setup.

Simplify the Process of Configuring Your SEL-487V Using the Graphical Logic Editor (GLE)

The GLE allows you to view your SELLogic control equations graphically, so your settings files can be documented for easier validation and commissioning. Convert existing SELLogic control equations to easy-to-read diagrams, and save diagrams with your ACSELERATOR QuickSet® SEL-5030 Software settings.

With the GLE capability in QuickSet, design new SELLogic control equations using the convenient diagram navigation tool, drag-and-drop interface, function block diagrams, and automatic layout function. Manage your control diagrams with a full element palette. The GLE will aid in reducing design errors as well as time and expense in commissioning relays.

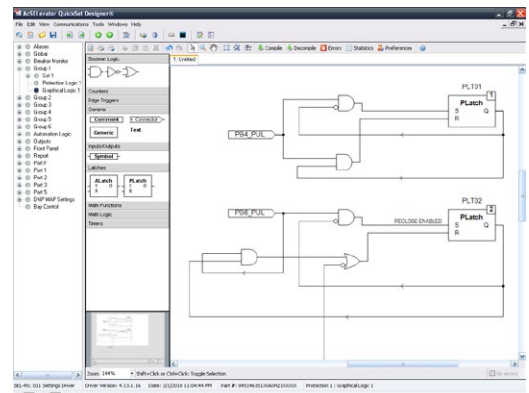

ACSELERATOR® graphical logic editor (GLE).

Applications

The SEL-487V Provides Comprehensive Protection and Control for Your Capacitor Bank Applications

Simplify relay settings, application, and inventory by using one relay for all of your capacitor bank needs. The versatile SEL-487V can handle grounded and ungrounded, single and double-ye capacitor bank configurations. It provides sensitive voltage differential and current unbalance protection with compensation adjustments for small inherent differences due to variations in individual capacitor elements from manufacturing or from instrument transformer measurement error. Each differential and unbalance element provides three levels of detection (low-set alarm, trip pickup, and high-level trip pickup), each with its own definite-time delay. Instantaneous, time-overcurrent, and directional-overcurrent elements as well as voltage elements provide backup protection.

Differential Protection

The voltage differential elements are used to detect variations in capacitor bank impedance due to loss of individual capacitor elements, a single capacitor unit, or an entire group of capacitor units. Filtering minimizes voltage transients due to line-switching operations.

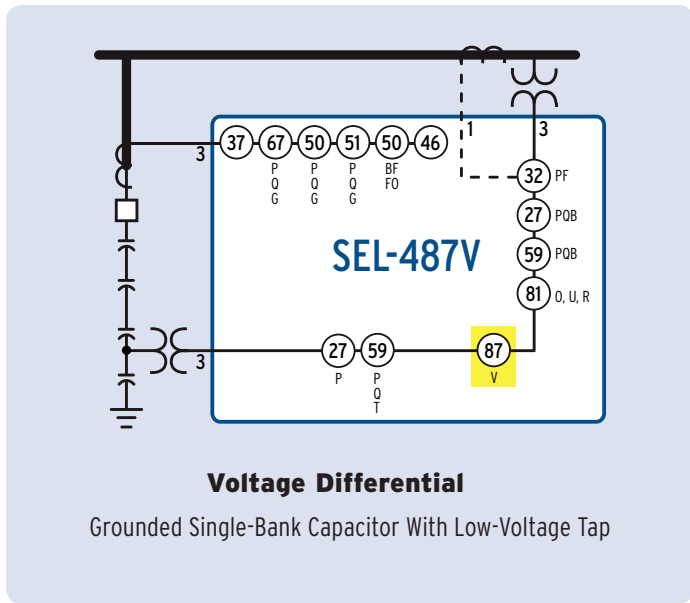

Phase Voltage Differential Elements

Protect grounded wye capacitor bank configurations with SEL-487V phase voltage differential elements. Three-phase voltage differential elements measure voltage differences between bus or line phase voltages and the tapped voltage of the grounded wye capacitor bank.

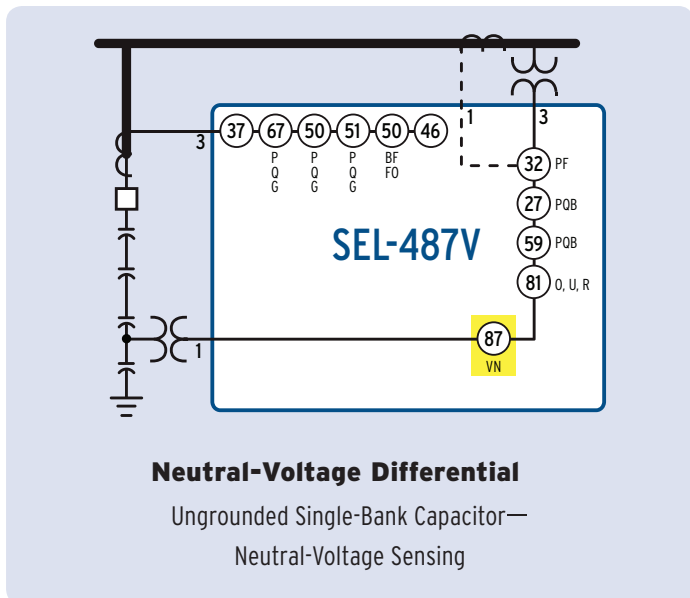

Neutral-Voltage Differential Elements

Protect up to three ungrounded wye capacitor bank configurations with SEL-487V neutral-voltage differential elements. Three neutral-voltage differential elements calculate zero-sequence voltage from three-phase potential inputs provided from the line or bus. The calculated zero-sequence voltage is then compared to the zero-sequence voltage measured by a potential transformer connected between the capacitor bank neutral and ground.

Unbalance Protection

Detect faulted capacitor elements with phase- and neutral-current unbalance elements, and receive indications of fault phase and direction. Fault phase and direction are based on the angle of the unbalance current relative to the positive-sequence current.

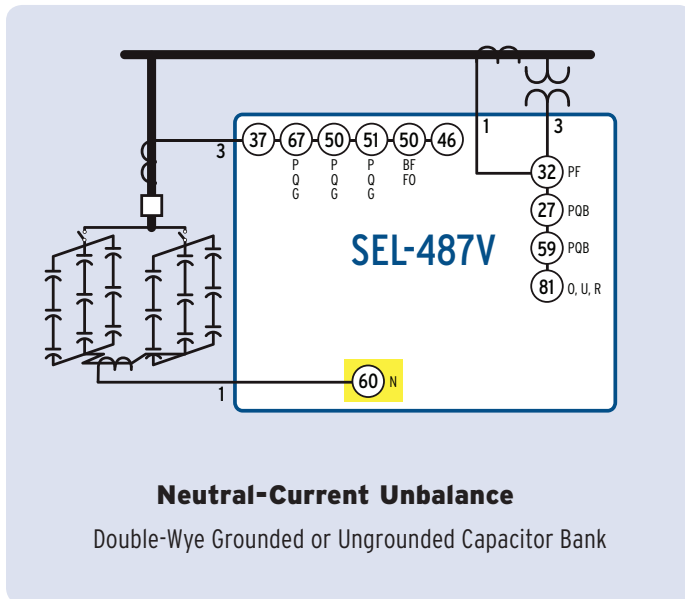

Neutral-Current Unbalance Elements

Protect ungrounded capacitor bank configurations with the SEL-487V neutral-current unbalance elements. Three elements provide protection for up to three double-wye capacitor banks.

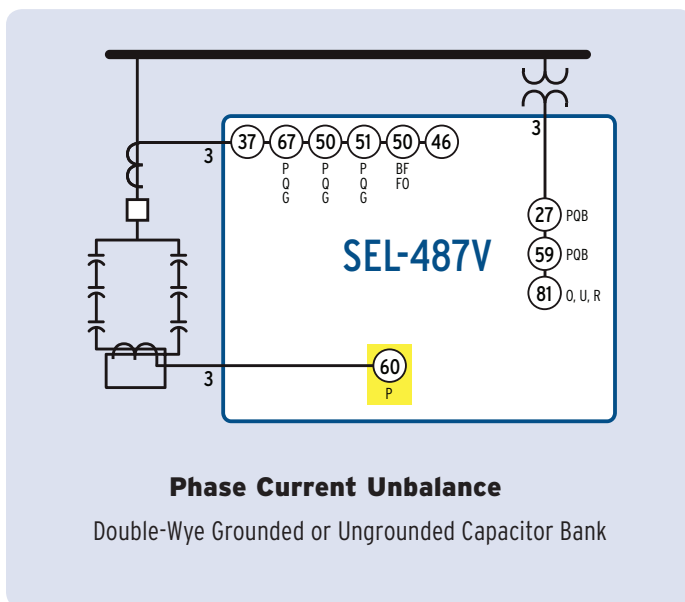

Phase Current Unbalance Elements

Protect both grounded and ungrounded double-wye capacitor bank configurations with the SEL-487V phase current unbalance elements. The SEL-487V provides three-phase current unbalance elements with nulling functions.

Additional Protection Elements

Current Elements

The SEL-487V provides phase, negative-sequence, and zero-sequence instantaneous overcurrent elements with torque and directional control as well as ten selectable operating quantity inverse-time overcurrent elements. In addition, there are six phase undercurrent elements with two pickup levels and torque control. The inverse-time overcurrent elements have two reset characteristics. One type resets the element after one cycle once the current drops below the pickup value, and the other emulates the reset characteristic of an electromechanical induction disc.

Voltage Elements

The SEL-487V provides six independent over- and undervoltage elements and six inverse-time overvoltage elements. The over- and undervoltage elements have two pickup levels, with the first having a definite-time delay. The inverse-time overvoltage elements track how long the bank has been in an overvoltage condition to indicate excessive wear on the bank. For all elements, choose from a wide range of fundamental and rms operating quantities for the two terminal voltage inputs.

Frequency Elements

The SEL-487V provides six frequency and six rate-of-change-of-frequency elements, driven from either of the terminal voltage inputs. The frequency elements can be configured for over- or under-frequency, and both frequency and rate-of-change-of-frequency elements provide a pickup time-delay setting. All frequency elements

are supervised by a programmable undervoltage element, which can be set to monitor either of the two potential inputs. This undervoltage element will block operations when the voltage input falls below the undervoltage supervision threshold.

Current Unbalance

The SEL-487V uses the average terminal current on one of the current terminals to calculate the percentage difference between the individual phase current and the terminal average current. If the percentage difference is greater than the set pickup value, the phase unbalance element is asserted. Terminal unbalance output is supervised using current fault detectors and the open-phase detection logic.

Thermal Elements

The SEL-487V implements three independent thermal elements that conform to the IEC 60255-149 standard. The elements operate on fundamental or rms phase currents, and each has separate alarm and trip levels. Use these elements to activate a control action or issue an alarm when the monitored equipment experiences operating conditions that could lead to a thermal overload.

Harmonic Metering

The SEL-487V includes the fundamental through the 15th harmonic for all voltage and current rms measurements, and includes total harmonic distortion (THD) as an analog quantity.

Breaker Failure Protection and Monitoring

Minimize System Clearing Times and Equipment Damage With Integrated Breaker Failure Protection and Monitoring

Incorporated into the SEL-487V is a full-function breaker failure system. High-speed, open-phase detection logic allows you to set the pickup current below minimum load for sensitivity without sacrificing high-speed dropout. Even in cases with subsidence current in the secondary of the CT caused by trapped flux, high-speed detection of the circuit breaker opening is achieved. This feature is essential if breaker failure is initiated on all circuit breaker trips. A reset of less than one cycle reduces coordination times, improving stability.

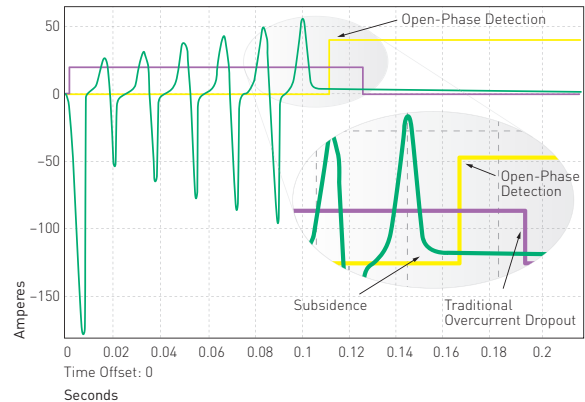

Breaker Flashover Detection

Rapidly Detect Breaker Flashover Conditions

The SEL-487V utilizes per-phase fundamental and rms current measurement to quickly detect breaker restrike and flashover across any one of the three breaker poles after the breaker is opened.

Because capacitor switching can place significant stress on a breaker, monitoring is crucial. SEL's enhanced event analysis recording has a resolution from 1-8 kHz to capture restrike and other breaker problems.

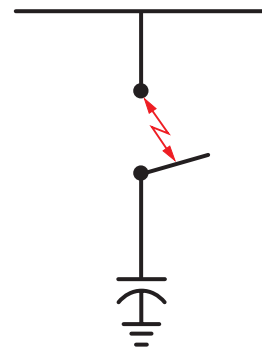

Synchrophasors

Improve Power System Quality and Save Money With SEL Synchrophasors (IEEE C37.118 or SEL Fast Message Protocols)

With synchrophasors over serial or Ethernet communications, detect reactive loop flows, turn state estimation into state measurement, and provide early warning of potential system instability. Measure system voltage angles to provide early warning of voltage collapse. Use configurable data streams to send unique phasor measurements from different ports (serial or Ethernet), and apply UDP multicasting to allow multiple clients to receive the same synchrophasor data.

Make informed system operational decisions based on actual real-time phasor measurements from across your power system. Use built-in time correlation, and take control actions based on combined local and remote messages. Apply control functions based on phase angles, currents, and voltages for basic or advanced applications.

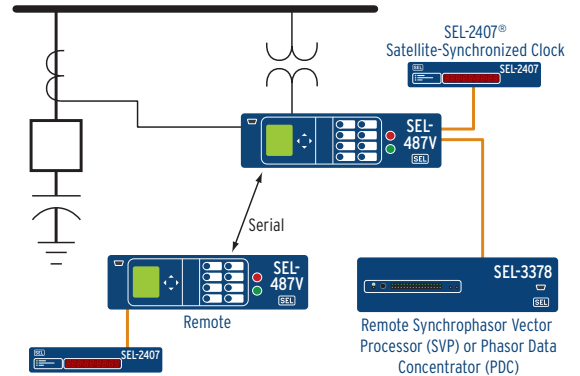

Use real-time control in the SEL-487V for simple applications and in the SEL-3378 for more complex applications.

IEC 61850 and Other Ethernet Protocols

Make Substation Integration and Automation Simple With Ethernet Communications

IEC 61850 Ethernet-based communications provide interoperability between intelligent devices within the substation. Logical nodes using IEC 61850 allow standardized interconnection of intelligent devices from different manufacturers for monitoring and control of the substation. Reduce wiring between various manufacturers' devices and simplify operating logic with IEC 61850. Add seamless failover protection to your system by using the parallel redundancy protocol (PRP) to provide zero-time recovery from a single point of failure in your Ethernet network. Provide basic time alignment throughout a substation over Ethernet with the simple network time protocol (SNTP). Eliminate system RTUs by streaming monitoring and control information from the intelligent devices directly to remote SCADA client devices using DNP3 LAN/WAN. Apply Telnet to access relay settings as well as metering and event reports remotely using the ASCII interface. Transfer settings files to and from the relay via the high-speed Ethernet port using FTP.

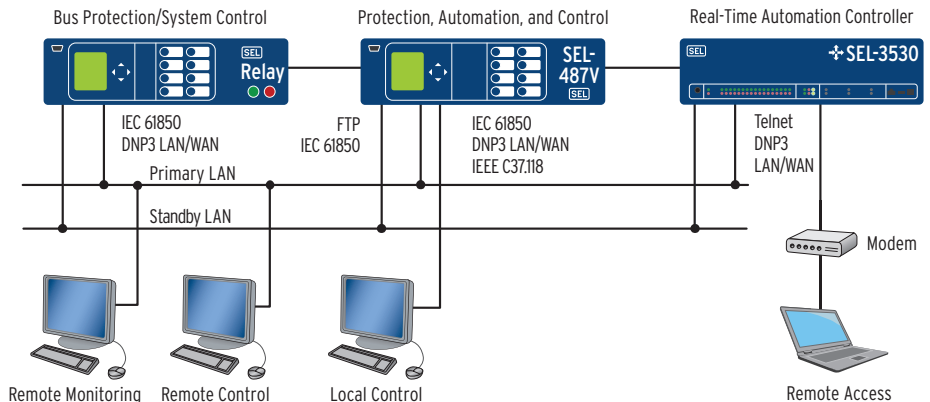

Enhanced MIRRORED BITS Communications

Transmit analog and digital information over high-speed serial communications paths:

- Send up to seven analog values or eight digital values on each MIRRORED BITS communications channel.
- Use virtual terminal MIRRORED BITS communications to get complete information from a remote relay with only a serial connection to the local relay.

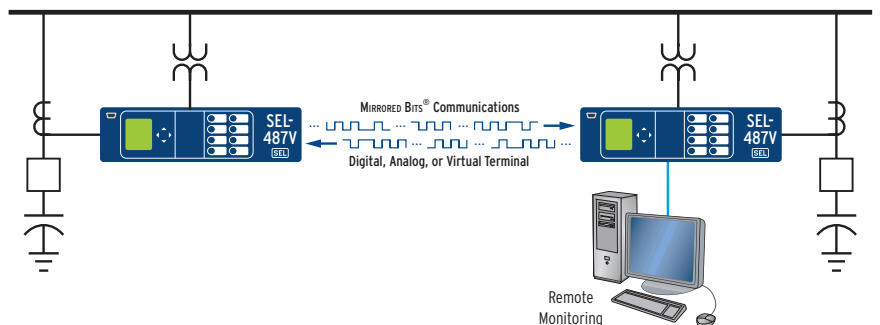

SEL-487V Capacitor Protection and Control System

General Specifications

AC Current Inputs (6 total)

1 A or 5 A I_{nom} (specify on order); 3 x I_{nom} continuous; 100 x I_{nom} one-second thermal rating; linear to 20 x I_{nom} symmetrical

Burden ≤ 0.5 VA @ I_{nom} for $I_{nom} = 5$ A;
 ≤ 0.1 VA @ I_{nom} for $I_{nom} = 1$ A

AC Voltage Inputs (6 total)

300 V_{L-N} continuous (connect any voltage up to 300 Vac)
600 Vac for 10 seconds

Burden ≤ 0.1 V @ 125 V

Output Contact Ratings (standard model)

30 A make per IEEE C37.90-1989 paragraph 6.7.2; 6 A continuous carry; MOV-protected

Optional high-speed and high-current interrupting
(10 A @ L/R = 40 ms) contacts available

Serial Communications Ports

Three rear-panel and one front-panel EIA-232 serial ports

SEL ASCII commands, SEL MIRRORING BITS, SEL Fast Messages, DNP3

Serial data speed 300–57600 bps

Processing Specifications

AC voltage and current inputs: 8000 samples per second, 3 dB low-pass analog filter cut-off frequency of 3000 Hz

Digital filtering: full-cycle and two-cycle cosine filters, after low-pass analog and digital filtering

Primary protection and control processing: 8 times per power system cycle

Synchphasors—IEEE C37.118 Standard

1–50 messages per second (50 Hz system)

1–60 messages per second (60 Hz system)

Power Supply

48/125 Vdc or 120 Vac 38–140 Vdc or 85–140 Vac (30–120 Hz)

125/250 Vdc or 120/240 Vac 85–300 Vdc or 85–264 Vac (30–120 Hz)

DC burden < 35 W

Typical power requirement 17.75 W @ 25°C

Ethernet Communications Options

Provides IEC 61850, DNP3 LAN/WAN, FTP, and Telnet protocols
Choose two media options from the following list:

10/100BASE-T twisted-pair network

100BASE-FX fiber-optic network

Frequency and Phase Rotation

60/50 Hz system frequency and ABC/ACB phase rotation are user-settable

Operating Temperature

–40° to +85°C (–40° to +185°F)

Note: LCD contrast impaired for temperatures below –20° and above +70°C

Humidity

5% to 95% without condensation

Weight (maximum)

4U rack-mount 9.8 kg (21.5 lbs)

5U rack-mount 11.6 kg (25.5 lbs)

